



CTT 210

STRETCH WRAPPER

CYKLOP[®]
GLOBAL PACKAGING SOLUTIONS

STRAPPING
WRAPPING
CODING
TAPING

CTT 210

STRETCH WRAPPER

The CTT 210 is a film wrapping machine that is easy and quick to operate: the operator places the pallet on the turntable, sets the wrapping program and cuts the film when the pallet is wrapped. The CTT 210 guarantees good load securement and minimum material costs. With this wrapping machine it is possible to adjust the tension yourself. Finally, the CTT 210 is extremely suitable for wrapping irregular pallet loads.

Advantages

- Easy and quick to operate
- Extremely suitable for wrapping irregular pallet loads
- Minimum material costs due to low film consumption

Options

- Bigger turntable
- Heightened mast
- Ramp
- Roping
- Scale
- Cutting unit



(mm)	A	B	C	D	E
Standaard	73	2305	2800	2475	1660

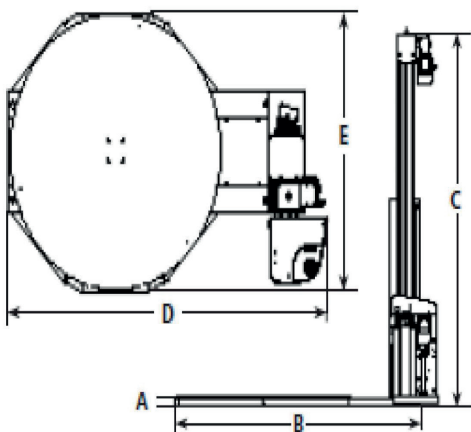

Technical data		
Machine	Turntable	Ø1650 mm
	Wrapping speed	12 rpm
	Start/stop	Frequency controller
	Filmcart speed	Adjustable
	Pre-stretch system	
	Pre-stretch percentage	80, 145 or 230%
	Programmes	5 standard and 1 optional
	Controller	PLC
Power	Supply Protection	Single phase 240V 50 Hz IP54
Pallet	Max. dimensions Max. height incl. pallet Weight	1200 x 1000 mm 2200 mm 2000 kg
Film	Core diameter Outer diameter, max Max. film width Film thickness	76 mm 250 mm 500 mm 9-35 micron

Cyklop UK Limited
Unit 2, Generation Business Park
Barford Road
St. Neots
Cambridgeshire
PE19 6YQ

+44 1480 216777
www.cyklop.co.uk
info@cyklop.co.uk

CYKLOP[®]
GLOBAL PACKAGING SOLUTIONS

STRAPPING
WRAPPING
CODING
TAPING