



CSM 220

ROBOT WRAPPER

CYKLOP[®]
GLOBAL PACKAGING SOLUTIONS

STRAPPING
WRAPPING
CODING
TAPING

CSM 220

ROBOT WRAPPER

The CSM 220 wrapping robot is ideal when flexible wrapping is required, the pallets are large in size or contain heavy objects and when the load is unstable. The wrapper can be moved to any desired location by means of a handle with operating buttons. The CSM 220 is equipped with a digital control panel that allows the user to change various settings and set custom wrapping cycle programs in an easy and functional way. The CSM 220 pre-stretches the film (up to about 66%) by means of a mechanical brake. The machine can wrap up to 120 pallets on one battery charge and the machine switches off automatically after 10 minutes of inactivity. This makes the CSM 220 low in energy consumption.

Advantages

- Ergonomic wrapping
- Economical: you save on film and the employee can do other work in the meantime
- The pallets are all wrapped in the same qualitative way
- You can move the machine to the workplace
- No need to pick up and move an unstable pallet
- No turntable, so it's easy to wrap large pallet sizes

Options

- Photocell for dark or reflective surfaces
- Car for net film
- Double track wheel
- Remote control
- Non-marking wheels
- Wheels for abrasive floor

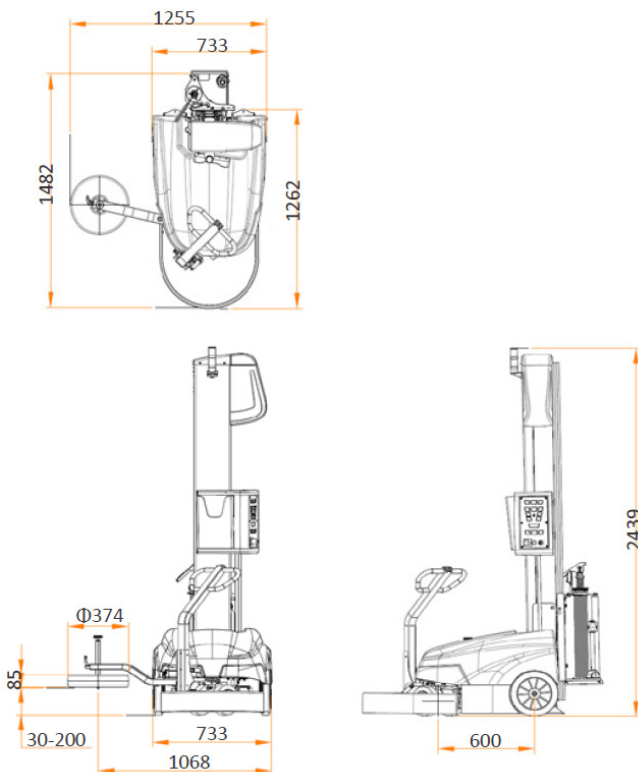
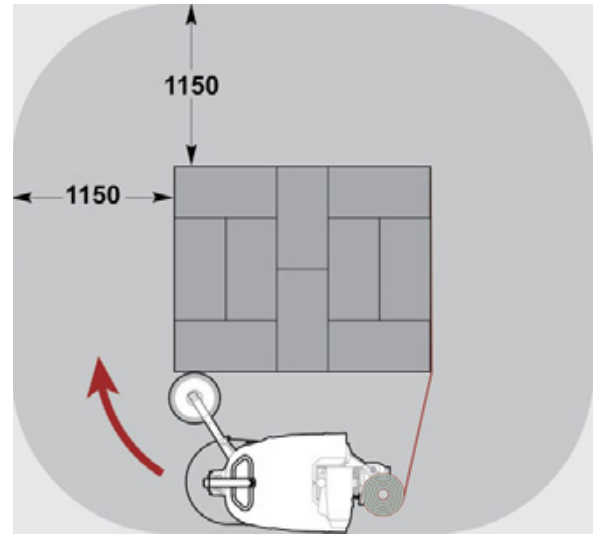

Technical data:

Max. pallet height	2100 mm
Min. pallet dimensions	400 x 500 mm
Max. pallet dimensions	6.000 x 7.000 mm
Min. pallet weight	20 - 55 kg (depending on wrapping film)
Power supply	100 – 240 V
Rotation speed	50 - 80 m/min
Max. noise	72,0 dB(A)
Environment temperature	5 – 40°C
Film roll	Width 500 mm Outer diameter 250 mm Core diameter 76 mm
Wrapping film	Weight 17 kg Up to 23 μ

Cyklop UK Limited
Unit 2, Generation Business Park
Barford Road
St. Neots, Cambridgeshire
PE19 6YQ

+44 1480 216777
www.cyklop.co.uk
info@cyklop.co.uk

CYKLOP[®]
GLOBAL PACKAGING SOLUTIONS

STRAPPING
WRAPPING
CODING
TAPING